

FEATURES:

- Blow-out Proof Stem
- Pressure Balance Hole in Ball Slot
- Various Thread Standards Available
- Casting Approved by TÜV AD 2000 - Merkblatt W0

APPLICABLE STANDARDS:

- Design : MSS SP-110
- Wall Thickness : EN 12516 - 3
- Pipe Thread **KV-030**: ASME B1.20.1
DIN 2999 / 259, ISO 228 / 1
JIS B 0203, ISO 7 / 1
- Butt Weld **KV-031**: ASME B16.25 (ØB2 Sch 40)
- Extended Butt Weld **KV-031-L**: ASME B16.25 (ØB2 Sch 40)
- Socket Weld **KV-032**: ASME B16.11
- Inspection & Testing: MSS SP-110



HEX.B

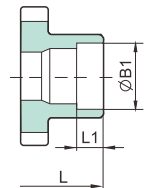
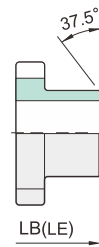
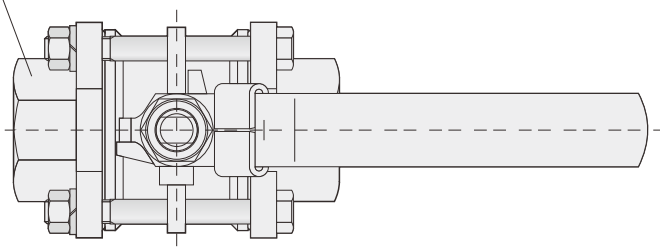

LB (Butt-welding Ends)

LE (Extended Butt-welding Ends)

SOCKET WELD END

| NO. | PART NAME | MATERIALS | | |
|-----|----------------|-------------------|------------------|-----|
| 1 | Body | CF8M | CF8 | WCB |
| 2 | Cap (Thread) | CF8M | CF8 | WCB |
| | Cap (Welding) | CF3M | CF3 | |
| 3 | Ball | CF8M | CF8 | |
| 4 | Ball Seat | | PTFE | |
| 5 | Stem | 316 | 304 | |
| 6 | Body Gasket | | PTFE | |
| 7 | Bolt | A193 - B8 / A2-70 | | |
| 8 | Thrust Washer | | PTFE | |
| 9 | Locking Device | | 304 | |
| 10 | Lever | | 304 | |
| 11 | Lever Sleeve | | Vinyl Plastic | |
| 12 | Stem Nut | | A194 - 8 | |
| 13 | Stem Washer | | 304 | |
| 14 | Gland Nut | | 304 | |
| 15 | Packing | | PTFE | |
| 16 | Bolt Washer | | 304 | |
| 17 | Bolt Nut | | A194 - 8 / A2-70 | |

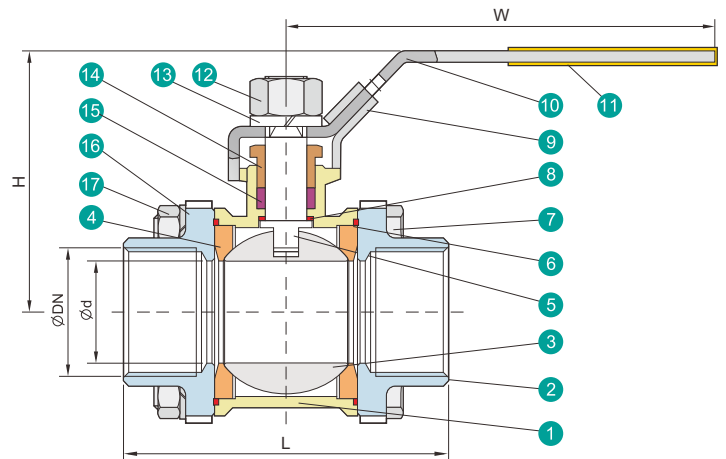

Unit: mm

| SIZE | d | L | LB | LE | H | W | L1 | B1 | B2 | B3 | HEX.B | DN |
|--------|------|-------|-------|-----|-------|-------|----|------|------|----|-------|--------|
| 1/4" | 10.6 | 65.2 | 65.2 | 225 | 57.5 | 100.0 | 10 | 14.2 | 9.3 | 18 | 23.5 | DN |
| 3/8" | 12.7 | 65.2 | 65.2 | 225 | 57.5 | 100.0 | 10 | 17.5 | 12.5 | 18 | 23.5 | NPT |
| 1/2" | 15.0 | 69.5 | 75.0 | 225 | 57.5 | 100.0 | 10 | 21.8 | 15.8 | 22 | 28.0 | BSP |
| 3/4" | 20.0 | 80.0 | 90.0 | 225 | 63.0 | 129.0 | 13 | 27.3 | 20.9 | 28 | 34.5 | PT |
| 1" | 25.0 | 90.0 | 100.0 | 245 | 75.5 | 156.0 | 13 | 34.0 | 26.7 | 34 | 42.0 | DIN |
| 1-1/4" | 32.0 | 110.0 | 110.0 | 255 | 81.0 | 156.0 | 16 | 42.8 | 35.1 | 43 | 52.0 | etc... |
| 1-1/2" | 38.0 | 120.0 | 125.0 | 260 | 94.0 | 182.5 | 16 | 49.0 | 40.9 | 50 | 58.5 | |
| 2" | 50.0 | 140.0 | 150.0 | 275 | 104.5 | 182.5 | 17 | 61.4 | 52.5 | 61 | 71.5 | |
| 2-1/2" | 63.5 | 185.0 | 190.0 | 330 | 131.0 | 252.0 | 17 | 74.0 | 62.7 | 76 | 86.5 | |
| 3" | 76.0 | 205.0 | 220.0 | 356 | 139.0 | 252.0 | 17 | 90.0 | 78.0 | 92 | 101.0 | |